

Redcord®

Sliding Suspension System

Installation Instruction

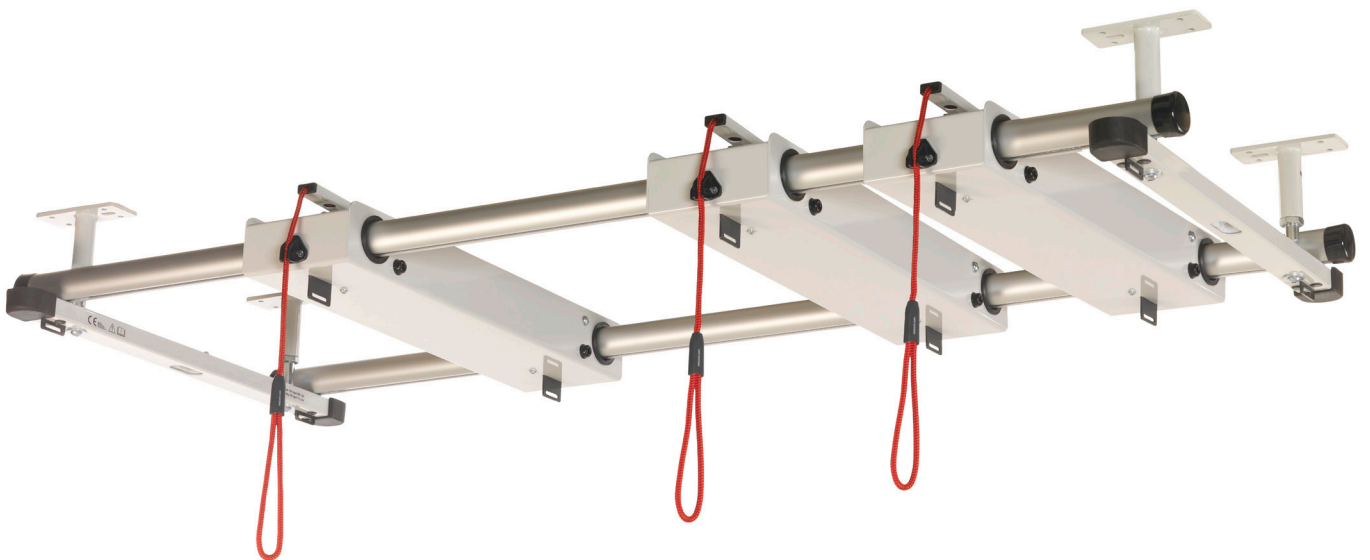

IMPORTANT:

Seek professional advice about the condition of the ceiling prior to the installation of the device. Redcord (nor its distributors) takes no responsibility for the suitability or condition of the ceiling in which the equipment is installed. Redcord takes no responsibility for third party suspension legs, attachments or components.

Redcord takes no responsibility for any personal or physical damages that might arise due to incorrect installation, and/or due to the ceiling, and/or incorrect use of Redcord equipment. Redcord does not recommend using the SSS for purposes other than supervised treatment. Sport activities and heavy exercises may increase the risk of damaging the equipment and/or the user for which Redcord will not be held accountable.

1. Necessary equipment for installation (NOT ENCLOSED)

1.1 For concrete ceiling

Hammer drill with a 8 mm concrete bit, set of hex (Allen) keys (bit 4, 5, 6), hammer, M30 and M13 open-end wrench.

1.2 For wooden ceiling

A drill, a set of hex (Allen) keys (bit 4, 5, 6), torx40, M30 open-end wrench.

2. Assembly for Redcord Sliding Suspension System (SSS)

Please assemble the entire system on the floor before mounting to the ceiling.

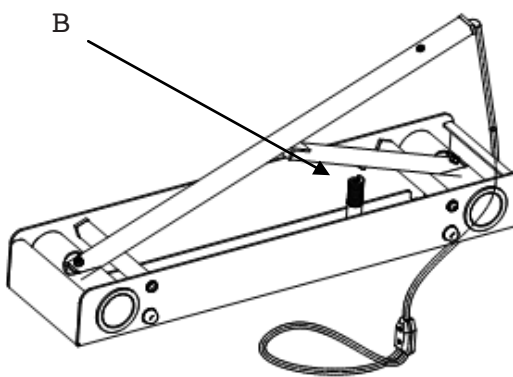

Unpack the traverse, lift the release arm as high as possible and put the spring (B) in place.

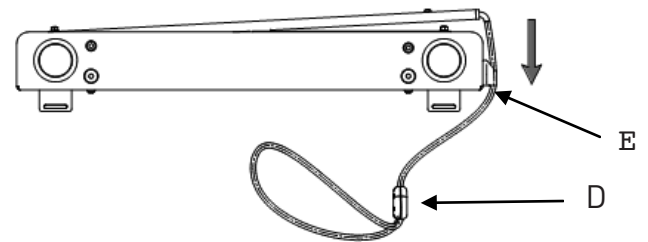

Pull the rope (D) down, so that the spring is fully compressed, and fasten the brake rope in the cleat (E). You can then easily slide the traverse on to the aluminum section.

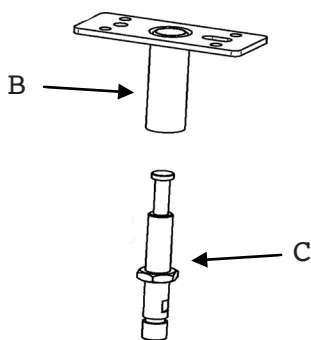

Assemble legs (B) to each bolts (C) mounted to the two crosspieces.

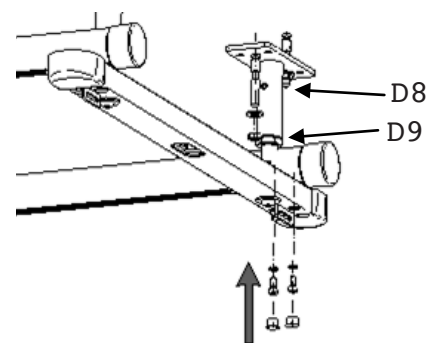

Fasten the safeguard (D8) and the M30 nut (D9). Do this for all four legs. Make sure you have the same length on all legs.

Assemble one crosspiece with the legs and the aluminum section. The aluminium section should be lying on the floor, with the crosspiece brackets facing upwards. Attach 2 screws (D3) in each end of the crosspiece. Put the black plugs (D5) in the screw hole after mounting is complete. Ensure that the safeguard (D8), the M30 nut (D9) and screw (D6) are fastened tight for the legs.

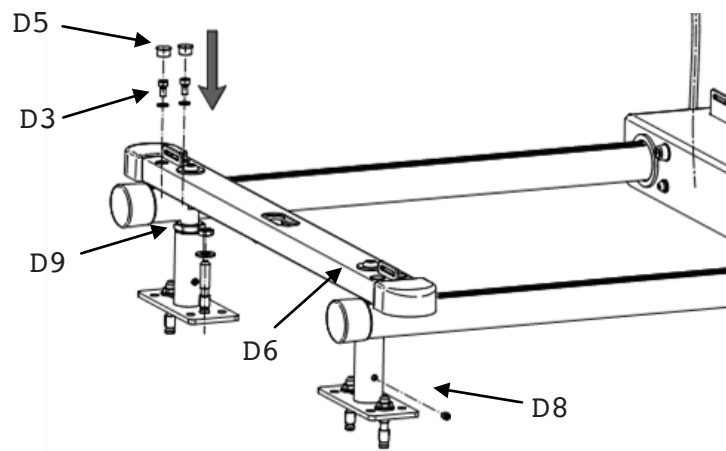

At the opposite end from the mounted crosspiece, temporarily remove the end caps on the aluminum section.



Slide the traverse onto the aluminium sections/rails by passing the 2 rails through the holes in the traverse.

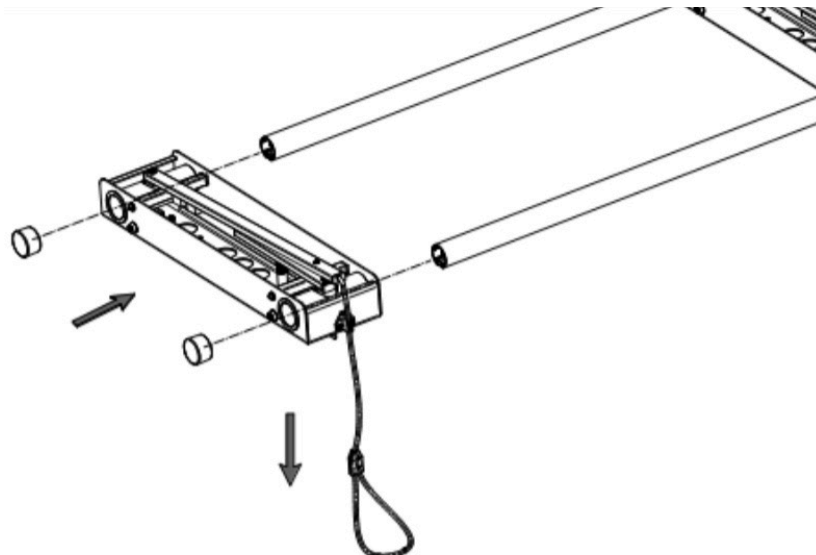

Put the end caps back on the aluminum sections. Ensure that the brackets on the traverse are facing up, and the brake lever arm is facing down. Ensure that both of the brake arms and the ropes are on the same side of the SSS for all three traverses.

Assemble the last crosspiece with the legs and the aluminum section.

The aluminium section should be lying on the floor, with the crosspiece brackets facing upwards. Attach 2 screws (D3) in each end of the crosspiece. Put the black plugs (D5) in the screw hole after mounting is complete.

Ensure that the safeguard (D8), the M30 nut (D9) and screw (D6) are fastened tight for the last two legs.

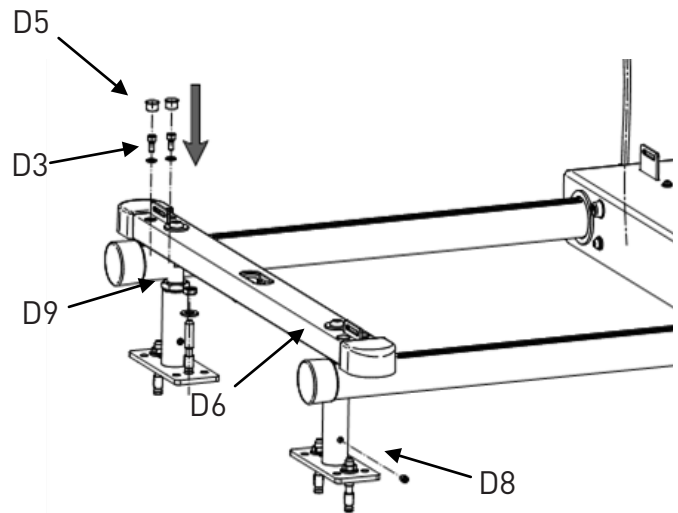

It is now possible to adjust the length of all legs by 3cm (1,2 inches).

Loosen the safeguard (D8) and the M30 nut (D9). Screw the legs (B) to desired length; fasten the safe-guard and the M30 nut again.

Do this for all 4 legs. Make sure all the legs have the same length before you mount the SSS to the ceiling.

Check also that the screw (D6) is well fastened for all 4 legs.

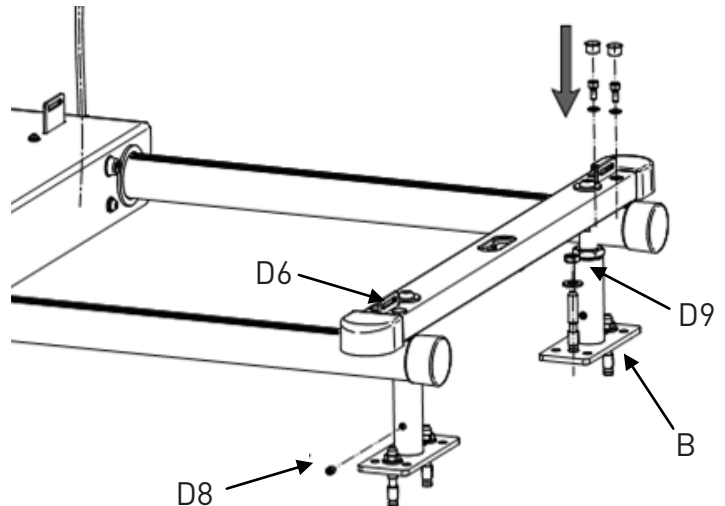

Before the Redcord Sliding Suspension System is installed to the ceiling, a sliding test of the three traverses have to be performed. The brackets on the traverses must face up and the break on each traverse has to be released with the break rope fasten in the cleat, see chapter 5.1.

Move all three traverses back and forth, the traverses shall slide easy on the 2 rails. If any problems are detected, please contact your supplier.

After the test has been performed, the Redcord Sliding Suspension System is now ready for ceiling installation.

To increase rigidity and eliminate chance of moving the traverse along the aluminum sections when installing the SSS to the ceiling, release the brake rope from the cleat again.

3. Mounting the SSS on to the ceiling

Find a suitable place to mount the system, see the drawing below min 60/80cm. The distances between the legs are 168 cm and 50cm. The space between the screw holes in the ceiling mounts is shown in the drawings below. Mark the points on the ceiling where the holes will be drilled. Check the distance between the holes. Drill the holes.

Note: If you have lowered ceiling, please read chapter 4 before you proceed.

3.1 Concrete ceiling

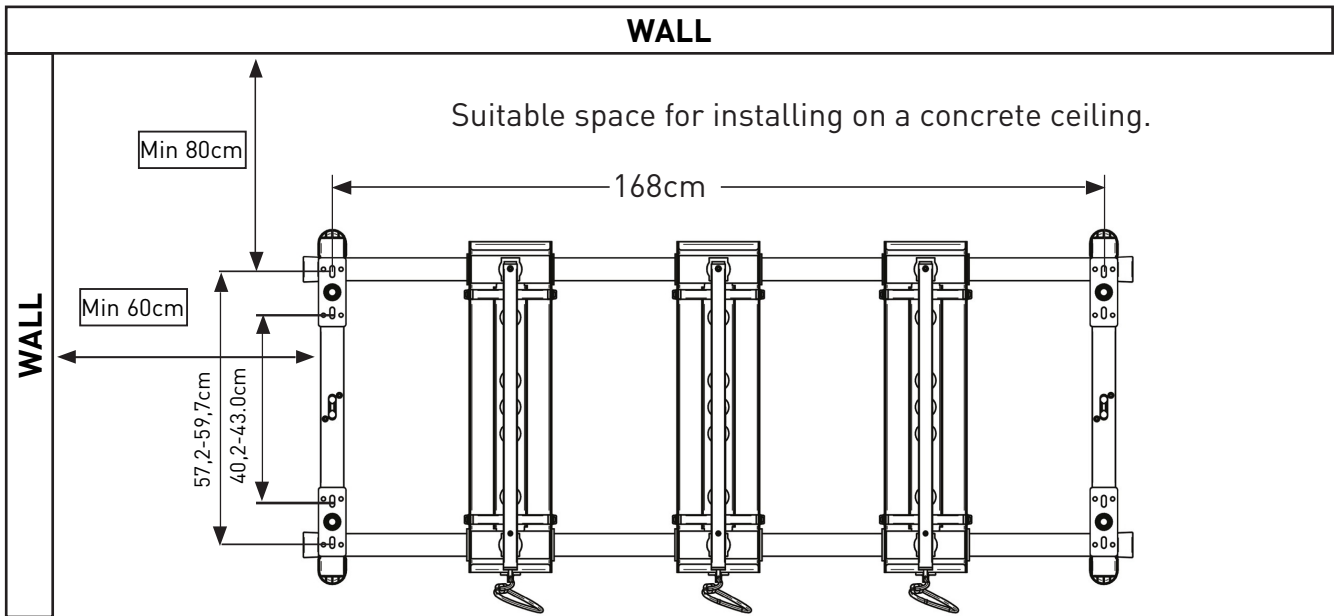

Drill 6 cm deep holes in the ceiling using a percussion drill with a 8mm bit for concrete. Pound in the split anchors and fastens the screws.

Minimum 2 screws for each leg are recommended.

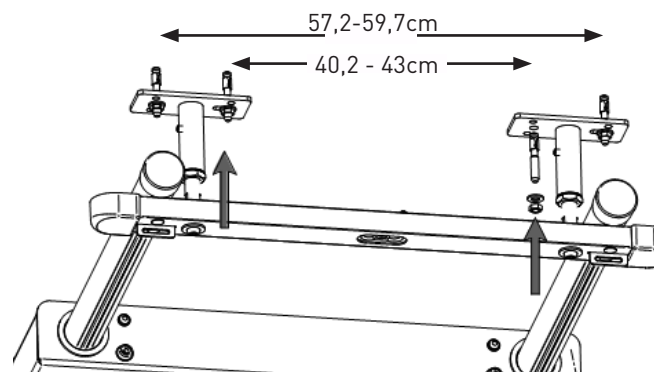

3.2 Wooden ceiling

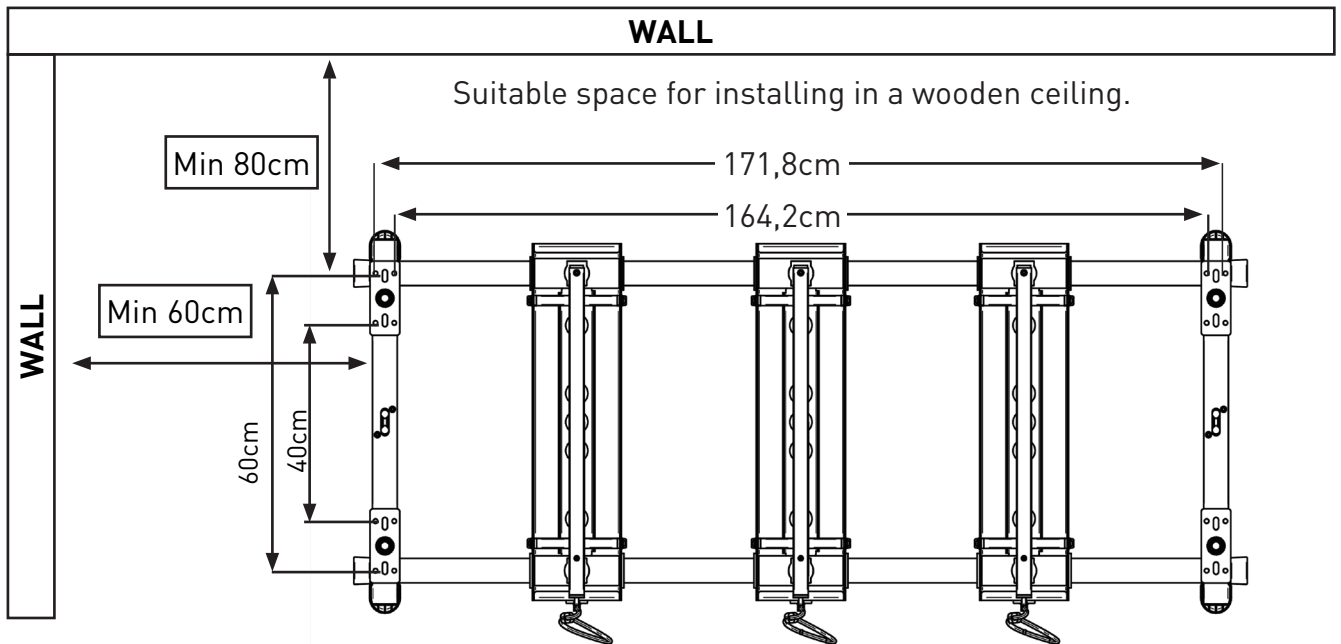

Drill the holes and fasten the legs with the 100mm screws supplied with the SSS. Minimum 2 screws for each leg are recommended. The screws are self-tapping and should be screwed in by using a torx 40 bit. Apply a small amount of oil, wax or soap to the screws to make the insertion easier.

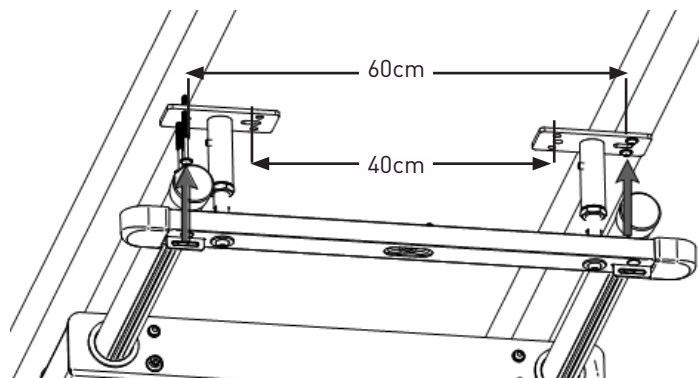

Suspend weight of about 150 kg at each corner, one corner at the time. The purpose of this weight test is to test the SSS installation, prior to using it for treating patients. It is possible to do the test by suspending yourself or two persons at each corner.

4. Mounting the SSS to a ceiling with lowered ceiling

Remove the ceiling panels where the legs are to be mounted to the ceiling above. Mount the system as directed above in chapter 3. Cut small holes into the side of the ceiling panels for legs of suspension system, and return the loose panels to their original position.

5. Operating the traverse

The traverses can be released and easily moved back and forth on the aluminium section during treatment. After reaching the desired position the traverses should be set in locked position.

5.1 Releasing the brake/traverse

To release the brake/traverse, pull down the brake rope and fasten it in the cleat (E). The traverse can now be pulled and moved in the required direction

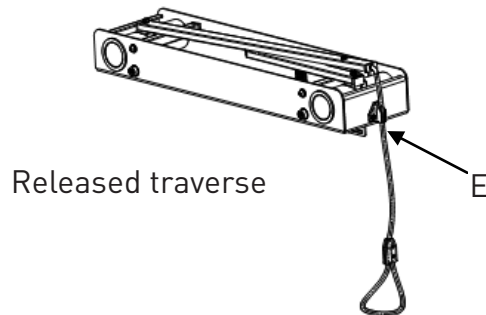

5.2 Locking the brake/traverse

To lock the brake/traverse, pull the brake rope simultaneously down and out releasing it out of the cleat. The brake/traverse is locked when the rope is let loose.

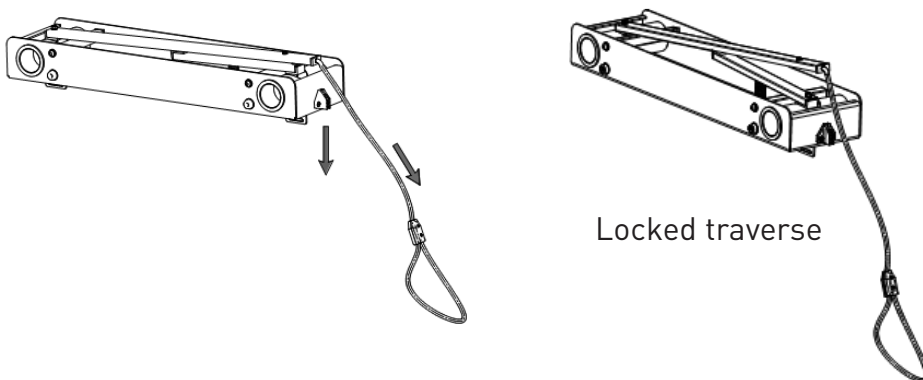

6. Security and maintenance

6.1 Security check

Grip the black plastic plugs at the end of the aluminum section and try to move the SSS vertically up and down as well as horizontally sideways. The SSS should be stable in all directions and make no noise.

Make sure:

1. All screws in the ceiling are securely tightened.
2. All screws (D3) that connect the crosspieces and the aluminum sections together are securely tightened
3. All screws (D6) that connect the legs to the crosspieces are securely tightened. If some of the screws are loose, tighten them well.
4. All screws (D8) on each leg (safeguard) are securely tightened.

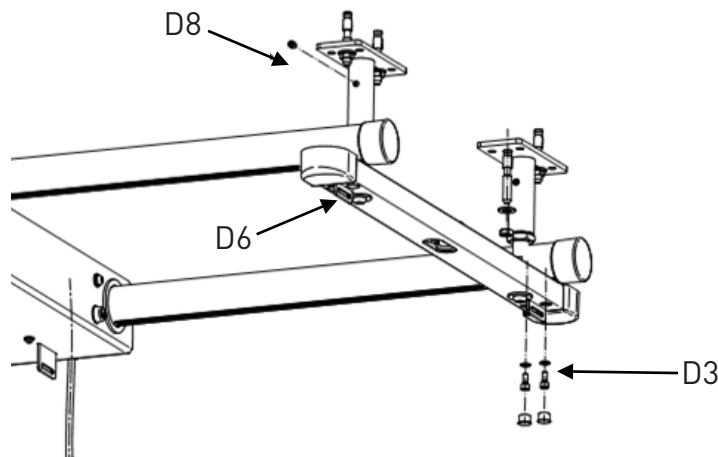

The Redcord Sliding Suspension System (SSS) should be checked on a monthly basis. The user must be sure that all screws and nuts are tightened well and that the suspension is stable in all directions. The frequency of this routine depends on how much the suspension is used, but we highly recommend that you perform a security check every month.

Please document your security check of the Sliding Suspension System (SSS). Redcord recommends that you use the form at the end of this document to record your findings.

6.2 Spare parts:

If you need screws for the ceiling, brake ropes or other parts to your SSS, contact your supplier. An overview of all suppliers can be found at www.redcord.com.

If additional legs and/or an extra traverse are required, please see guidelines for add/change traverse/legs at redcord.com

NOTE: Only original screws from Redcord must be used.

6.3 Maintenance and cleaning of your SSS:

Keeping your SSS clean is the best maintenance you can perform. Regular cleaning of your SSS will secure proper function. By following these guidelines you will ensure proper function for many years.

Dust should be removed from the SSS with a vacuum cleaner or dry dust cloth.
NB! Remove dust from inside the traverses.

If washing is required use a soft cloth and hot water. Do not use detergent or soap.

Do **NOT** use lubricant of any kind on the aluminium sections or the traverses.
Lubricant (oil, grease, silicone etc will:

1. Reduce (and in worst case disable) the brake function of the traverse
2. Attract dust
3. Increase friction and lead to poor operation of your SSS

7. Maintenance form

Security check for Sliding Suspension System (SSS) (See instruction in chapter Security and maintenance, chapter 6)

| | Date: | Security check performed by: | Result: |
|----|-------|------------------------------|---------|
| 1 | | | |
| 2 | | | |
| 3 | | | |
| 4 | | | |
| 5 | | | |
| 6 | | | |
| 7 | | | |
| 8 | | | |
| 9 | | | |
| 10 | | | |
| 11 | | | |
| 12 | | | |
| 13 | | | |
| 14 | | | |
| 15 | | | |
| 16 | | | |
| 17 | | | |
| 18 | | | |
| 19 | | | |
| 20 | | | |
| 21 | | | |
| 22 | | | |
| 23 | | | |
| 24 | | | |
| 25 | | | |
| 26 | | | |
| 27 | | | |
| 28 | | | |
| 29 | | | |
| 30 | | | |
| 31 | | | |
| 32 | | | |
| 33 | | | |
| 34 | | | |



4846 Arendal
Tlf: +47 37 03 00 00
redcord@redcord.com
www.redcord.com